



CD3 Products Manual

RevA-21MAY20

This page intentionally left blank.



Table of Contents

Section 1 – General Unit Overview	6
1.1 Unit Model Descriptions	6
1.1.1 Station.....	6
1.1.2 Wayside 120V.....	6
1.1.3 Wayside Solar.....	7
1.1.4 Outpost.....	7
1.1.5 Trailer Option (Wayside 120V and Wayside Solar Only).....	8
1.2 Unit Layouts and Features	9
1.2.1 Overview Station/Wayside - Front.....	9
1.2.2 Overview- Station/Wayside - Rear.....	10
1.2.3 Overview – Outpost.....	11
1.3 Unit General Specifications	12
Section 2 – Before Operation	13
2.1 Installation	13
2.1.1 Stationary Mounting.....	13
2.1.2 Electrical Install (Station, Wayside 120V).....	14
2.2 Safety Information	16
Section 3 – Unit Operation	17
3.1 Main Power Shut-Off Switch	17
3.2 All Off Button (Station/Wayside Only)	17
3.3 Vacuum System (Station/Wayside Only)	18
3.3.1 Vacuum Intended Use.....	18
3.3.2 Vacuum Safety Information.....	18
3.3.3 Vacuum Button Operation.....	19
3.3.4 Vacuum Hose.....	19
3.3.5 Tank Capacity.....	19
3.4 Blower System (Station/Wayside Only)	20
3.4.1 Blower Intended Use.....	20
3.4.2 Blower Safety Information.....	20
3.4.3 Blower Button Operation	21
3.4.4 Blower Hose	21
3.4.5 Blow Gun	22
3.4.6 Compressor Operation.....	22
3.5 Hand Tools	23
3.5.1 Cable Reels.....	23
3.5.2 Brush	23
3.5.3 Reach Grabber	23
3.5.4 Plug Wrench.....	23
3.6 Lights	24



Table of Contents

3.7 Trailer (Wayside 120V and Wayside Solar Only)	25
3.7.1 Trailer Intended Use	25
3.7.2 Trailer Safety Information	25
3.7.3 Trailer Lowering/Crank Down Procedure.....	28
3.7.4 Solar Panel Tie Down (Trailerred Wayside Solar Only)	29
3.8 Battery Charging (Trailerred Wayside Units Only)	30
3.8.1 Charging Procedure.....	30
3.8.2 Charger Safety Information	31
3.8.3 Extension Cord Requirements.....	31
3.8.4 Partial Recharging	31
3.8.5 Charge Time.....	31
3.8.6 Battery Break-In.....	32
3.8.7 Depth of Discharge	32
Section 4 – Maintenance and Care	33
4.1 Vacuum System (Station/Wayside Only)	33
4.1.1 Tank Emptying	33
4.1.2 Vacuum Pressure Relief Valve.....	34
4.1.3 Inspect Hose.....	34
4.2 Blower/Compressor (Station/Wayside Only)	35
4.2.1 Blower/Compressor Maintenance Safety.....	35
4.2.2 Air Pressure Regulator	36
4.2.3 Relief Valve.....	36
4.2.4 Air Filter.....	37
4.2.5 Air Leaks.....	37
4.2.6 Compressor Oil.....	38
4.2.7 Compressor Belts (Station Only).....	38
4.3 Tool Reels	39
4.3.1 Reel Lubrication.....	39
4.3.2 Cable Inspection.....	39
4.3.3 Tension Adjustment	39
4.3.4 Spring Replacement	39
4.3.5 Reel Sensors.....	39
4.3.6 Tool Replacement	39
4.4 Batteries (Wayside/Outpost Only)	40
4.4.1 Battery Safety Precautions.....	40
4.4.2 Battery Pack Inspection	41
4.4.3 Battery Cleaning	41
4.4.4 Battery Disposal.....	41
4.5 Fuses	42



Table of Contents

4.6 Trailer (Wayside120V and Wayside Solar Units Only)	43
4.6.1 Greasing Wheel Bearings	43
4.6.2 Tire Pressure	44
4.6.3 Lift System Inspection	44
4.7 Storage/Winterization	45
4.7.1 Cover	45
4.7.2 Compressor in Storage (Station/Wayside Only)	45
4.7.3 Batteries in Storage (Wayside/Outpost Only)	46
4.8 Care and Cleaning	47
4.9 Key Replacement	47
4.9 Maintenance Schedule Table	48
Section 5 – Theory of Operation	49
5.1 Control System	49
5.1.1 Control Module	49
5.1.2 Cellular Gateway	49
5.1.3 Function Buttons	53
5.2 Station	54
5.2.1 Compressor	54
5.2.2 Vacuum	54
5.2.3 Lights	54
5.3 Wayside (Solar and 120V)	55
5.3.1 Battery Pack	55
5.3.2 Solar Panels/Solar Charging	55
5.3.3 120V Charger	55
5.3.4 Compressor	55
5.3.5 Vacuum	56
5.3.6 Lights	56
5.4 Outpost	57
5.4.1 Battery Pack	57
5.4.2 Solar Panels/Solar Charging	57
5.4.3 Light	57
Section 6 – Digital Tools	58
6.1 Web Resources	58
Section 7 – Customer Assistance Information	59
Section 8 – Warranty Statement	60



Section 1 – General Unit Overview

1.1 Unit Model Descriptions

1.1.1 Station

The Station unit is designed to be mounted in a single location and permanently affixed to a concrete base. It has a large industrial wet or dry vacuum, a compressed air blower, and three hand tools. The hand tools include a long-handled brush, plug wrench, and reach grabber, all attached to cable reels for tool retention. The unit is illuminated with two lights at the lower edges of the body and two on a light pole centered above the body.

The Station differs from its siblings in that it is powered by 220VAC power, which powers an industrial grade compressor and vacuum motor to power the equipment. It is not power limited in the use of any of its features.



1.1.2 Wayside 120V

The Wayside 120V unit retains the same outer functions of the Station (vacuum, blower, and three hand tools). It differs from the Station unit in that 120VAC powers it via a battery pack and charger. This unit uses the stored energy to provide a similarly functioning vacuum and blower. The Wayside 120V uses an on-demand tank-less compressor for the blower, which produces similar output as the station unit. The difference is that it draws power only when used and does not have an air compressor tank. The vacuum is still an industrial-grade but has slightly less energy due to the supply power limitations. Those power supply limitations also amount to a lower amount of consecutive run time than the Station unit. This unit can function as a stationary unit and be mounted to a concrete pad like the Station, where it would need supply power and just remain plugged in. The battery pack can also be mounted to a trailer frame for mobility between use sites.





Section 1 – General Unit Overview

1.1 Unit Model Descriptions

1.1.3 Wayside Solar

The Wayside solar unit is designed to be mounted in a single location and permanently affixed to a concrete base. It retains the same outer functions of the Station and Wayside 120V (vacuum, blower, and three hand tools). It also contains the same compressor, vacuum, and battery configuration as its closest sibling, the Wayside 120V unit. It differs from the Wayside 120V in that it uses its solar panels to charge the battery pack instead of requiring a 120VAC power source. The componentry is all the same, but it uses a solar charger instead of a 120V supply charger to feed the battery pack. The limitations of the unit are the power supply that it uses. The energy constraints result in a lower amount of consecutive run time than the Station or Wayside unit. Recharge time is also variant depending on the location specifics. The main benefit of the solar function is that this unit requires no on-site power supply.



1.1.4 Outpost

The Outpost unit differs the most from the other models. It is a much-simplified version that uses only three hand tools and lights. Like the Wayside units, it is powered by a battery pack. The pack is appropriately sized to accommodate its much less power demand than the Wayside units. The only powered features in the Outpost are the lights and the internal logic system. It also uses solar panels to supply power, so no on-site power supply is required. The outpost is only limited in consecutive uses of the light function.





Section 1 – General Unit Overview

1.1 Unit Model Descriptions

1.1.5 Trailer Option (Wayside 120V and Wayside Solar Only)

The Wayside solar unit is designed to be mounted in a single location and permanently affixed to a concrete base. It retains the same outer functions of the Station and Wayside 120V (vacuum, blower, and three hand tools). It also contains the same compressor, vacuum, and battery configuration as its closest sibling, the Wayside 120V unit. It differs from the Wayside 120V in that it uses its solar panels to charge the battery pack instead of requiring a 120VAC power source. The componentry is all the same, but it uses a solar charger instead of a 120V supply charger to feed the battery pack. The limitations of the unit are the power supply that it uses. The energy constraints result in a lower amount of consecutive run time than the Station or Wayside unit. Recharge time is also variant depending on the location specifics. The main benefit of the solar function is that this unit requires no on-site power supply.





Section 1 – General Unit Overview

1.2 Unit Layouts and Features

1.2.1 Overview Station/Wayside - Front

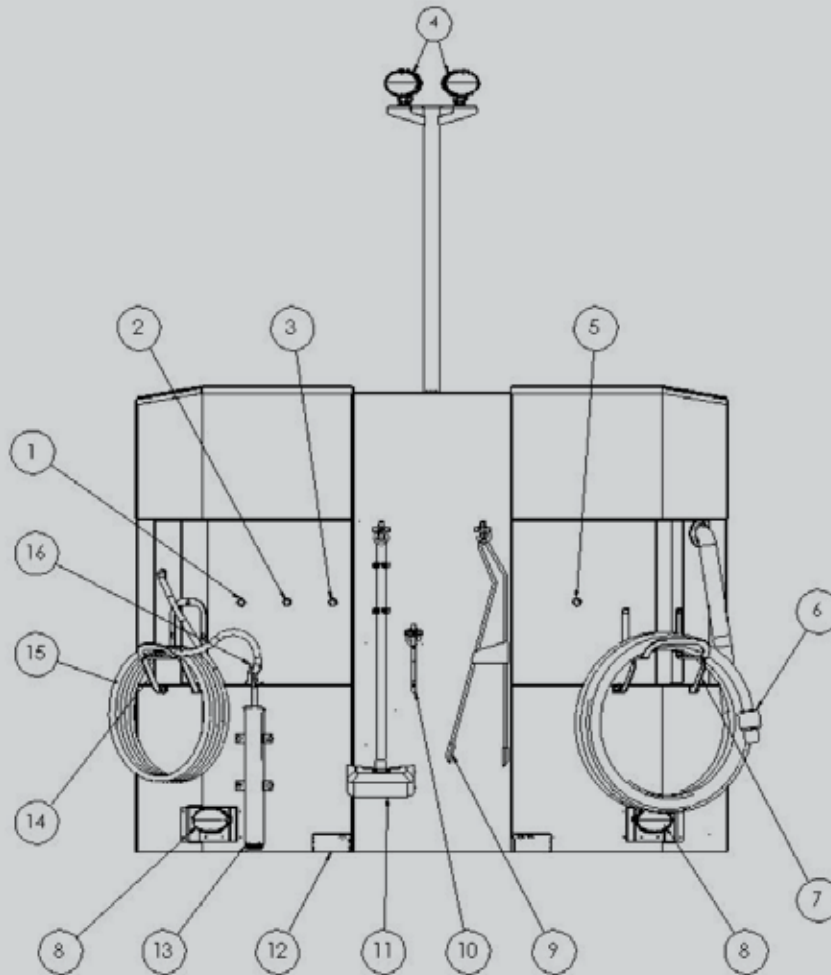

- | | |
|---|--|
| 1. Blower Function Button (sec. 3.4.3) | 9. Reach Grabber (Tool 3) (sec. 3.5.3) |
| 2. Light Function Button (sec. 3.6) | 10. Plug Wrench (Tool 2) (sec. 3.5.4) |
| 3. "All Off" Function Button (sec. 3.2) | 11. Brush (Tool 1) (sec. 3.5.2) |
| 4. Upper Lights (sec. 3.2) | 12. Fork Tunnel |
| 5. Vacuum Function Button (sec. 3.3.3) | 13. Air Blow Gun Holster |
| 6. Vacuum Hose (sec. 3.3.4) | 14. Air Blow Gun Hose Rack |
| 7. Vacuum Hose Rack | 15. Air Blow Gun Hose (sec. 3.4.4) |
| 8. Body Light (sec. 3.2) | 16. Air Blow Gun (sec. 3.4.5) |



Section 1 – General Unit Overview

1.2 Unit Layouts and Features

1.2.2 Overview- Station/Wayside - Rear

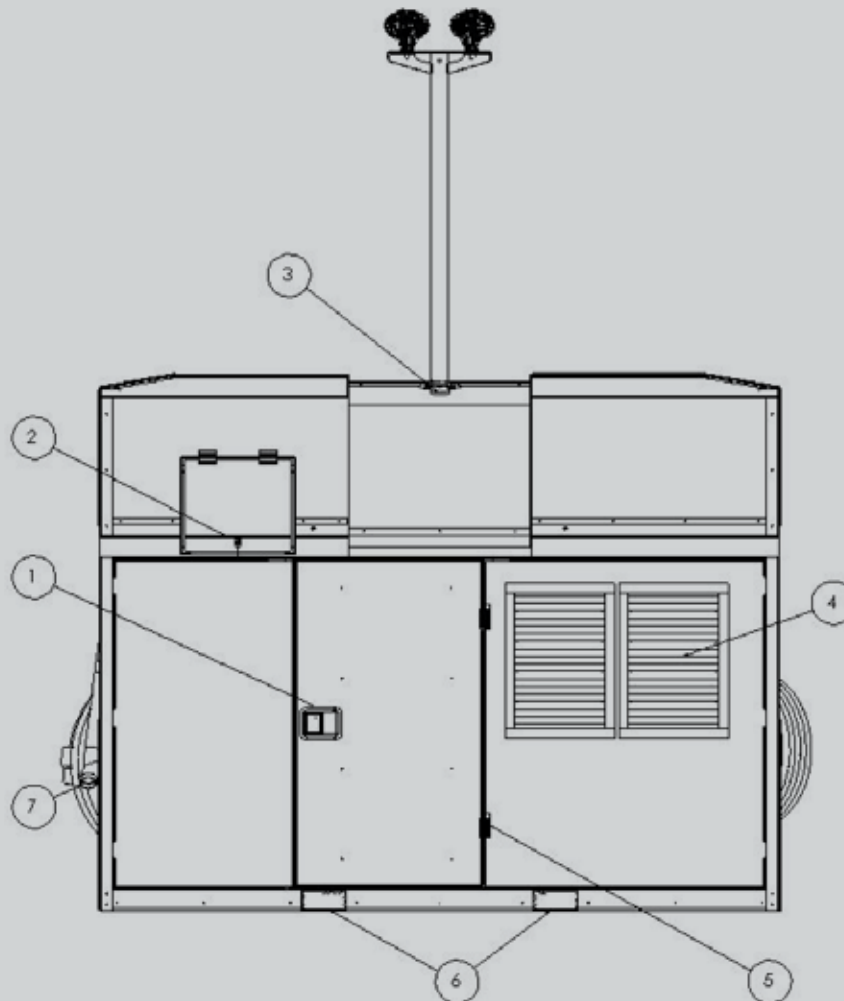

- | | |
|-----------------------------|---------------------------------|
| 1. Service Door | 5. Service Door Lift-Off Hinges |
| 2. Vacuum Tank Clean-Out | 6. Fork Tunnel |
| 3. Data Logger Antenna | 7. Vacuum Exhaust Outlet |
| 4. Compressor Cooling Vents | |



Section 1 – General Unit Overview

1.2 Unit Layouts and Features

1.2.3 Overview – Outpost

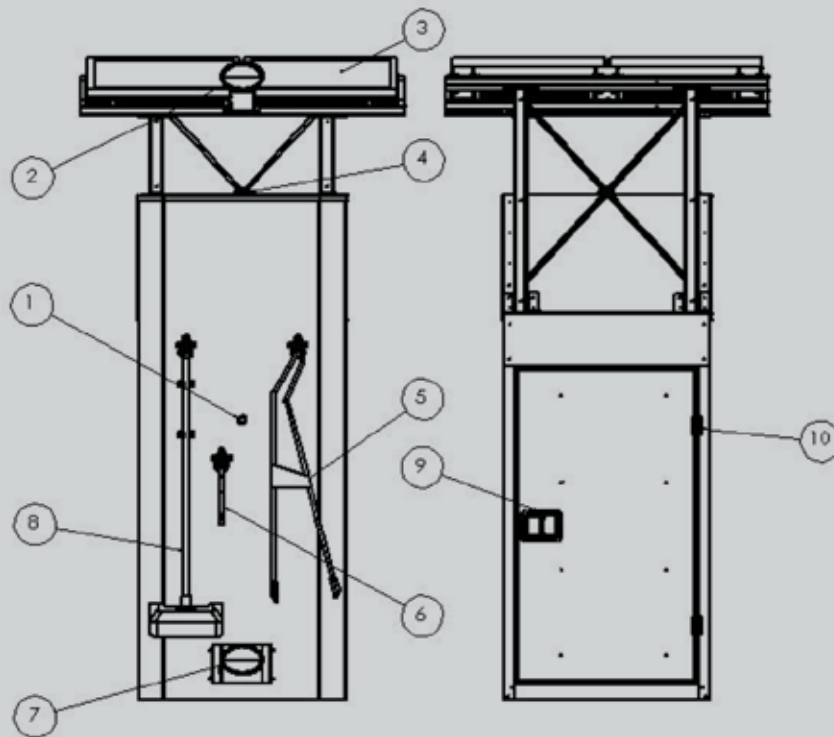

- | | |
|---------------------------------------|--------------------------------------|
| 1. Light Button Function (sec. 3.6) | 6. Plug Wrench (Tool 2) (sec. 3.5.4) |
| 2. Upper Light (sec. 3.6) | 7. Lower Light (sec. 3.6) |
| 3. Solar Panels | 8. Brush (Tool 1) (sec. 3.5.2) |
| 4. Data Logger Antenna | 9. Service Door |
| 5. Reach Grabber (Tool 3)(sec. 3.5.3) | 10. Service Door Lift-Off Hinges |



Section 1 – General Unit Overview

1.3 Unit General Specifications

Specification Table



General	Station	Wayside 120V	Wayside Solar	Outpost
Overall Height (in)	71.25	71.25	93.5	89.25
Overall Width (in)	92.75	92.75	131.8	44.85
Overall Depth (in)	45.5	45.5	45.25	27.5
Light Pole Height (in)	119.5	119.5	119.5	-
Vacuum Tank Capacity (gal)	108	108	108	-

Tools

Grabber Reach (in)	28	28	28	28
Brush Reach (in)	35	35	35	35
Tool Reel Cable Length (ft)	50	50	50	50
Blow Gun Reach (in)	24	24	24	24
Blow Pressure (psi)	90	90	90	-
Air Hose Diameter (in)	0.375	0.375	0.375	-
Air Hose Length (ft)	35	35	35	-
Vacuum Hose Diameter (in)	2	1.5	1.5	-
Vacuum Hose Length (ft)	25	25	25	-

Electrical

Supply Voltage (VAC)	240	120	-	-
Supply Current (A)	30	15	-	-
Supply Frequency (Hz)	60	60	-	-
Solar Panel Output (W)	-	-	540	100



Section 2 – Before Operation

2.1 Installation

Trained professionals should perform the installation process. Large machinery may be needed for proper installation. Be sure to have operators qualified in the operation of the machinery and licensed where necessary.

2.1.1 Stationary Mounting

The unit is intended to be mounted to a concrete pad. The unit's base should be affixed to this mounting surface (see instructions below) before attempting to use the equipment. The concrete base should be prepared using the available concrete frame for stud and electrical location or the CD3 pre-cast concrete base. The following instructions assume the concrete base has already been prepared.

2.1.1.1 Installation Procedure (Station or Wayside units)

1. Remove rear door and panels. The door can be removed by swinging it all the way open and lifting whereabouts the hinges will separate. Three Phillips-head screws will remove the adjacent panels along with the door jamb for each panel. Remove the screws, swing the panel out slightly and pull away from the body to release the tabs. Removing these panels will allow access to the mounting bracket locations. Having the panels off also allows better sighting of the mounting studs while placing the unit on the concrete.
2. Place the unit on the concrete mounting base. Use the fork tunnels accessible from the unit's front or back to lift and place the unit on the concrete base. Take care not to damage the mounting studs while placing the unit. The five studs should be located in the open spaces just inside the primary base frame beams.

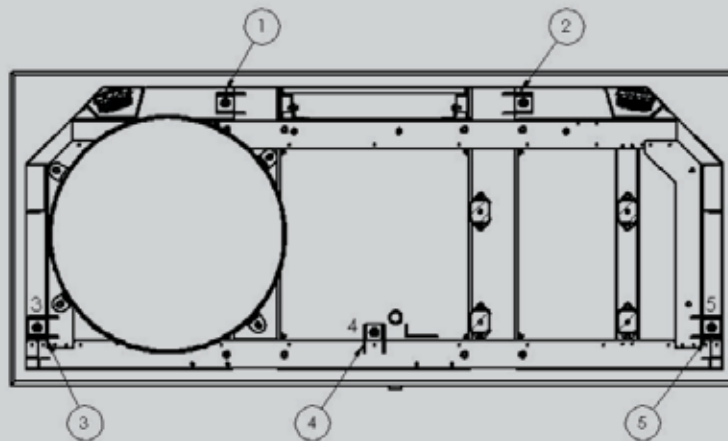

3. Install the mounting brackets, as shown in the above diagram. Install and tighten the hardware. Note: The mounting brackets may be studs in the concrete or threaded inserts. Hardware to match either should be included in the mounting kit.



Section 2 – Before Operation

2.1 Installation

2.1.1.1 Installation Procedure (Station or Wayside units) *cont'd*

4. Drive grounding rod into the ground and attach the ground wire. There is a small hole on the side corner near the unit's compressor for routing the grounding wire out. Route the wire through the hole and connect to the grounding rod. The grounding rod preferred location is in a 24" radius of that corner of the unit.
5. Plug the unit into its power source (if applicable) and re-install the rear panels. The station unit will plug into the electrical box from the concrete base where the wayside units may plug into a 120V outlet in the same location or not at all, depending on the unit configuration. Re-install the rear panels and door in the reverse order of disassembly.

2.1.1.2 Installation Procedure (Outpost)

1. Remove the rear door by swinging it all the way open, and lifting and the hinges will separate. Removing the door will allow the ability to manipulate the unit position without the door swinging around.
2. Place the unit on the concrete mounting base by lifting it over the mounting studs and locating it to align with the mount holes. Take care not to damage the mounting studs while placing the unit. The four studs should locate in the corresponding base frame holes.
3. Install the mounting hardware and tighten. Note: The mounting may be studded in the concrete or threaded inserts. Hardware to match either should be included in the mounting kit. Re-install the door in the reverse order it was removed.

2.1.2 Electrical Install (Station, Wayside 120V)

2.1.2.1 Safety Warnings

1. Improper connection of the equipment-grounding conductor can result in a risk of electric shock.
2. Check with a qualified electrician or service person as to whether the outlet is grounded.
3. Do not modify the appliance's plug – if it does not fit the outlet, have a proper outlet installed by a qualified electrician.
4. Make sure that the appliance is connected to an outlet having the same configuration as the plug.
5. No adapter should be used with this appliance.
6. No extension cord should be used with this appliance.



Section 2 – Before Operation

2.1 Installation

2.1.2.2 Power Supply

STATION

Voltage: 195-265 volts AC (Single Phase)

Max Power Consumption: 6600 watts

Frequency: 60 hertz

The unit can be plugged into any 230V 30A (NEMA 6-30) outlet. The electric socket must be a 230V 30A correctly connected and protected by a current-fault circuit breaker. The installation must comply with local rules and regulations.

*Electric wiring must be conforming to National Electrical Code NFPA 70 or NF C 15100 standards or must comply with standard regulation in activity inside the country to the power mains supply. The presence of grounding (earth) wire and a frame with a proper ground-fault protection breaker is mandatory.

WAYSIDE 120V

Voltage: 85-138 volts AC (Single Phase)

Max Power Consumption: 960 watts

Frequency: 50-60 hertz

The unit can be plugged into any 125V 15A (NEMA 5-15R) outlet. The electric socket must be of the type NEMA 5-15R three-hole outlet 125V 15A correctly connected and protected by a current-fault circuit breaker. The installation must comply with standard regulations in activity inside the country to the power mains supply.

*Electric wiring must be conforming to National Electrical Code NFPA 70 or NF C 15100 standards or must comply with standard regulation in activity inside the country to the power mains supply. The presence of grounding (earth) wire and a frame with a proper ground-fault protection breaker is mandatory.

2.1.2.3 Grounding

A grounding rod should be installed with all units mounted to the ground. The unit should be grounded directly. No splices or connections are allowed in the ground wire between the unit and the ground rod. The minimum grounding wire to run to the unit should be eight gauge. It is vital to get a good, solid connection. Avoid making 90° or sharper turns with the ground wire. A lightning charge has difficulty making such a turn and, therefore, may discharge somewhere else. Make ground wire bends as smooth and as gradual as possible. The ground wire must be connected to a ground rod. Water pipes or plumbing fixtures are not acceptable. A good copper-coated steel ground rod driven into the ground is required (See local building codes for rod specifications and required depth). Special clamps that provide a solid connection between the ground wire and ground rod should be used.



Section 2 – Before Operation

2.2 Safety Information



ATTENTION! - Read all safety rules carefully before attempting to operate. Failure to comply can result in accidents involving fire, electric shock, or serious personal injury. Save this operator's manual and review it frequently to continue safe operation and instruct others who may use this equipment.

DANGER! Never operate this unit when flammable materials or vapors are present because electrical devices produce arcs or sparks that can cause a fire or explosion. NEVER OPERATE UNATTENDED!

WARNING! Do NOT use this vacuum cleaner to vacuum lead paint debris because this may disperse fine lead particles into the air. This vacuum cleaner is not intended for use under EPA Regulation 40 CFR Part 745 for lead paint material cleanup.

To reduce the risk of injury, everyone using, installing, repairing, maintaining, changing accessories on, working near this equipment must read and understand these instructions before performing any such task.



Safe operation of this piece of equipment requires that you read and understand this operator's manual and all labels affixed to the unit. Safety is a combination of common sense, staying alert, and knowing how your tool works.

WARNING – TO REDUCE THE RISK OF FIRE, ELECTRIC SHOCK, OR INJURY:

1. Practice safety requirements. Stay alert, have proper attire, and do not operate tools under the influence of alcohol or drugs.
2. Always inspect equipment for damage before use. Loose hoses or fittings can create dangerous situations.
3. Always wear ANSI-approved safety goggles when working with tools and equipment.
4. Do not modify any part of the unit to perform any task they were not intended as described in this manual.
5. Never point the blowgun or blow compressed air at peoples or animals.
6. Do not allow it to be used as a toy. Close attention is necessary when used by or near children.
7. Use only as described in this manual.
8. Do not use with damaged cord or plug. If the unit is not working as it should or has been damaged, contact CD3 for assistance.
9. Keep the power cord away from heated surfaces.
10. Do not unplug by pulling on the cord. To unplug, grasp the plug, not the cord.
11. Do not handle the plug with wet hands.
12. Do not use any openings blocked; keep free of dust, lint, and anything that may reduce airflow. Do not place or store anything to block cooling air intake or exhaust openings on the unit. Component damage may result.
13. Keep hair, loose clothing, fingers, and all parts of the body away from openings and moving parts.
14. The tools are intended to be operated as handheld tools. It is always recommended that while using the tools, operators stand on solid ground, in a secure position with a firm grip and footing.
15. Turn off the main shut-off switch before unplugging.
16. Danger - DO NOT allow tool cables to retract in an uncontrolled manner. Always guide cable back to reel. Failure to do so can result in damage to the reel or personal injury.



Section 3 – Unit Operation

3.1 Main Power Shut-Off Switch

The Unit is equipped with a master power shut-off switch that removes any current draw from the system. The switch is located inside the rear service door and mounted to the electrical component plate straight inside. The switch has about a three-inch diameter dial. Turn the switch clockwise to apply power and counter-clockwise to disconnect power. This switch should be disengaged before any maintenance or repairs are performed on the unit.

*Wayside and Outpost Units Note: The shut-off switch still needs to be in the “On” position to be able to charge the batteries either by solar means (Wayside Solar and Outpost) or by battery charger (Wayside 120V).



Station



Wayside



Outpost

3.2 All Off Button (Station/Wayside Only)

The All Off button is to cancel all functions of the unit at any time during their use. The button is to be used in any scenario where the functions need to be interrupted. Pushing this button will cancel any timer of an operation and cancel its operation immediately. The actuation button for any functions can be pushed again to turn them back on if desired, but the timer for the function will start over. It is important to note that this button does not cancel electricity the machinery for servicing. It only shuts down any active function from the user's perspective.





Section 3 – Unit Operation

3.3 Vacuum System (Station/Wayside Only)

3.3.1 Vacuum Intended Use

The vacuum is intended for wet and dry operations. It is meant to clean debris from a watercraft and/or watercraft trailer of all types on the inside or outside. Any organic debris can be removed with the vacuum. Please place inorganic material in the appropriate trash containers. The vacuum is intended for debris, plants, and animals. The vacuum can be used to remove the water as well as the bait from the container. The vacuum is also intended to remove any water from a watercraft in any location.

3.3.2 Vacuum Safety Information



WARNING – TO REDUCE THE RISK OF FIRE, ELECTRIC SHOCK, OR INJURY:

1. Do not allow the vacuum to operate if the hose is blocked. If air is not permitted to flow through the vacuum motor while running, motor damage may occur.
2. Do not block the exhaust air from the vacuum or restrict it as motor damage may occur.
3. Do not use the vacuum to pick up anything burning or smoking, such as cigarettes, matches, or hot ashes.
4. Do not use the vacuum to pick up flammable or combustible liquids such as gasoline or use them in areas where they may be present.
5. Do not vacuum toxic, carcinogenic, combustible, or other hazardous materials such as asbestos, arsenic, barium, beryllium, lead, pesticides, or other health-endangering materials. Specially designed units are available for these purposes (this unit is not one of them).
6. Do not pick up soot, cement, plaster, or drywall dust. These are very fine particles that may pass through the system and affect the motor's performance or be exhausted back into the air.
7. The operation of a vacuum can result in foreign objects being blown into eyes, resulting in eye damage. Always wear eye protection when operating the vacuum.
8. STAY ALERT. Watch what you are doing and use common sense. Do not use the vacuum when you are tired, distracted, or under the influence of drugs, alcohol, or medication causing diminished control.
9. WARNING! Do NOT use this vacuum to vacuum lead paint debris because this may disperse fine lead particles into the air. This vacuum is not intended for use under EPA Regulation 40 CFR Part 745 for lead paint material cleanup.



Section 3 – Unit Operation

3.3 Vacuum System (Station/Wayside Only)

3.3.3 Vacuum Button Operation

The orange light in the lighted vacuum actuation button indicates that it is ready to operate. The vacuum will turn on instantly with the push of the actuation button. The button will then begin to flash while the vacuum is in operation. The operation window/timer is for two minutes, at which point the vacuum will turn off. During the two-minute operation window, the button will flash at a rate of about one second on, one second off for the first one minute and 30 seconds. The button can be pushed again during this part of the operation window to turn it off. During the last 30 seconds of the time window, the button light will flash at a rate of about one-half second on and one half second off. During this final 30 seconds, pushing the button again will continue the vacuum's operation and reset the operation for another two-minute time window. The operation can also be canceled by the "all off" red button at any point during operation. The light on the button may flash at a rate of 2 flashes per second, and pushing the button will not activate the vacuum. This sequence indicates that the tank is full and will need to be emptied (see sec. 4.1.1). The vacuum will not operate until the collection tank has been emptied. If the button light is flashing in a manner other than described in this section, it is a system fault signal. Contact a qualified CD3 service person.



3.3.4 Vacuum Hose

The vacuum hose is a 25' long, 2" (1.5" for Wayside) flexible vacuum hose. The hose should be coiled on the provided hanger when not in use. Hanging the hose will prevent possible damage from occurring, such as a vehicle driving over it. Any hose that is broken, constricted, plugged, or damaged in any way should be replaced as soon as possible. A damaged hose will reduce the suction of the vacuum and potentially cause damage to the vacuum motor. Do not pull excessively on the hose at the body attachment point, as it may damage the unit's internal plumbing.

3.3.5 Tank Capacity

The tank is intended for organic material only and has a capacity of 108 gallons. The tank is equipped with a sensor that indicates the level of capacity remaining and can be viewed through the online data site (see Section 5). The tank is also equipped with a float switch that will shut the vacuum down when the tank reaches maximum capacity and does not allow the vacuum to be turned on again until it is emptied. The actuation button for the vacuum will flash to indicate that the float switch is actuated and the tank is at full capacity (see sec. 3.3.3).



Section 3 – Unit Operation

3.4 Blower System (Station/Wayside Only)

3.4.1 Blower Intended Use

The air blower dispenses a stream of air at 90 psi, which works well to remove small water pockets from tough-to-reach places. The blower can be used to aid in the removal of weeds or aquatic life in or on the watercraft. It can also be used to dry places of water within the watercraft.

3.4.2 Blower Safety Information



Warning - To reduce the risk associated with pneumatic pressure and other mechanical hazards:

1. The air produced by this unit is not fit for human or animal consumption, and it must not be used to provide a breathing air supply.
2. It is recommended to always wear ANSI-approved safety goggles when working with the blowgun.
3. STAY ALERT. Watch what you are doing and use common sense. Do not use the blowgun when you are tired, distracted, or under the influence of drugs, alcohol, or medication causing diminished control.
4. Keep out of the reach of children.
5. Do not modify the system to dispense air at any pressure exceeding 90 PSI.
6. Do not modify any part of the air blow gun set to perform any task for which it was not designed.
7. NEVER point the blowgun or blow compressed air toward the face or any part of the body of yourself, others, or animals.
8. Never blow air directly on yourself while operating the blowgun.
9. Whipping hoses can cause serious injury. Always check for damaged or loose hoses and fittings before use.
10. If the air hose is severed or punctured for any reason, push the "all off" button immediately and do not reactivate the blower function until the hose is replaced.

Only press the "all off" button if it is safe to do so; a severed hose may make the air hose move around or whip back and forth under pressure. If this is the case, do not approach the unit unless it is safe to do so. If necessary, let the time expire for the operation.



Section 3 – Unit Operation

3.4 Blower System (Station/Wayside Only)

3.4.3 Blower Button Operation

The orange light in the lighted blower actuation button indicates that it is ready to operate. The blowgun will become active instantly with the push of the actuation button. Actuating the blower function will pressurize the air hose for the blowgun but not dispense any air by this operation alone. The trigger on the blowgun itself will need to be depressed to dispense pressurized air. Once active, the button will begin to flash while the blower is operating (i.e., pressure to the air hose). The operation window/timer is for two minutes, at which point the blower will turn off. During the two-minute operation window, the button will flash at a rate of about one second on, one second off for the first one minute and 30 seconds. The button can be pushed again during this part of the operation window to turn it off. In the last 30 seconds of the time window, the button light will flash at a rate of about one-half second on, one-half second off. During this final 30 seconds, pushing the button again will continue the blower's operation and reset the operation for another two-minute time window. The operation can also be canceled by the "all off" red button at any point during operation. Note that the blower function's cancellation will still leave air in the air hose if the blowgun trigger has not been depressed to relieve it. The gun will blow for a few seconds after that function has been canceled. If the button light is flashing in a manner other than described above, it is a system fault signal. Contact a qualified CD3 service person.



3.4.4 Blower Hose

The blower hose is a 35' long, 3/8" diameter flexible rubber air hose. The hose should be coiled on the provided hanger when not in use. Coiling the hose will prevent possible damage from occurring, such as a vehicle driving over it. Any hose that is broken, constricted, plugged, or damaged in any way should be replaced immediately. A damaged hose is not just a detriment to the unit's performance, but it's a potential safety hazard for a user. Do not pull excessively on the hose at the body attachment point, as it may damage the unit's internal plumbing.

Warning! – If the air hose is severed or punctured for any reason, push the "all off" button immediately and do not reactivate the blower function until the hose is replaced. Only press the "all off" button if it is safe to do so; a severed hose may make the air hose move around or whip back and forth under pressure. If this is the case, do not approach the unit unless it is safe to do so. If necessary, let the time expire for the operation.



Section 3 – Unit Operation

3.4 Blower System (Station/Wayside Only)

3.4.5 Blow Gun

The hand-held blow gun is intended to be held in the palm using the fingers to grip the gun's body and the thumb to actuate the trigger. Air is only dispensed when the trigger is pushed down, so if a steady stream of air is desired, the trigger will need to be held down. The extended length of the gun is to reach difficult areas to reach with the hand or arm. The blowgun's tip sprays a stream of air through the middle and a cone of air around it to protect against debris fly-back. This design is a safety feature. However, eye protection should still be worn while operating the blowgun. Replace the blowgun in its storage sleeve when not in operation to prevent damage.



3.4.6 Compressor Operation

3.4.6.1 Station (220V)

The compressor is set up with a 30-gallon tank that runs as the tank needs air, and the air is fed for the blowgun from that tank. The result is that the compressor runs slightly disconnected from the blowgun operation. More use of the blowgun will create the compressor to run more, but the blowgun operating does not necessarily mean that the compressor will come on. The compressor will run as a function of the collective air volume used.

3.4.6.2 Wayside

The compressor is an on-demand compressor with no tank, so the compressor will run only while the blowgun trigger is depressed. The compressor may run for a few seconds when the actuation button is pressed, but only to pressurize the air hose if it is not already pressurized.



Section 3 – Unit Operation

3.5 Hand Tools



Warning! – Keep hair, loose clothing, fingers, and all parts of the body away from openings and moving parts.

3.5.1 Cable Reels

Each tool is attached to a 50-foot cable that is pre-tensioned with ratcheting stops. The reel extends to the cable's full length and is retractable by a torsion spring on the reel. The tension to pull out the cable will then be stronger the more cable that is pulled out. The tension on the cable can be relieved and lock the cable length in any position. The ratcheting lock can be engaged by pulling the cable out to the desired position and letting it retract SLOWLY until the lock engages. To release the lock, quickly pull the cable out a short distance and allow it to begin to retract. The locking feature may be turned off by turning the knob on the reel's side, accessible from the rear service door.

3.5.2 Brush

The brush is intended to remove larger sections of small weeds, algae, or anything else from the watercraft hull to obtain a complete cleaning. Hold the brush firmly in both hands to operate effectively.



3.5.3 Reach Grabber

The reach grabber tool gives the user the extended reach beyond the normal to remove lake weeds hanging from a watercraft or trailer. The grabber assists a user that has a difficult time bending or leaning over to reach these weeds or someone that just needs a more extended reach. Hold the grabber in either hand at the handled grip end and squeeze the two bars together to grasp at the pinchers. Release the grip and allow the bars to separate to release at the pincher end.



3.5.4 Plug Wrench

The plug wrench is a multi-use tool that can remove Garboard and T-handle style drain plugs from the watercraft. The plug wrench is a drain plug removal tool that allows quick and comfortable removal of the drain plug without added strain. It is specially designed not to damage the plug or watercraft as well.





Section 3 – Unit Operation

3.6 Lights

The unit is equipped with high visibility, white light, LED lights. Two are built into the lower unit body (one in the case of an outpost), and two are on a light pole (one on the solar rack in the case of the Outpost). These are located to provide full light for accessing the tools on the unit in any situation.

The orange light in the illuminated light actuation button indicates that the lights are ready to operate. The lights will become active instantly with the push of the actuation button. Actuating the light function will turn on all the lights on the unit at one time. Once operational, the button will begin to flash while the lights are active. The operation window/timer is for ten minutes (seven minutes on the Wayside and Outpost units), at which point the lights will all turn off. During the operation window, the button will flash at a rate of about one second on, one second off for all of the time except for the time window's final 30 seconds. The button can be pushed again during this part of the operation window to turn it off. In the last 30 seconds of the time window, the button light will flash at a rate of about one-half second on, one-half second off. During this final 30 seconds, pushing the button again will continue the lights' operation and reset the operation for another time window. The operation can also be canceled by the "all off" red button at any point during operation. If the button light is flashing in a manner other than described above, it is a system fault signal. Contact a qualified CD3 service person to resolve it.



Station



Wayside/Outpost



Section 3 – Unit Operation

3.7 Trailer (Wayside 120V and Wayside Solar Only)

3.7.1 Trailer Intended Use

The optional trailer is intended to allow the unit to be moved from site to site and lowered to the ground at each location for ease of use and immobility once placed. When equipped, the unit is bolted to the trailer and not intended to be readily removed. It is designed to be road-ready to travel on any regular road. However, the trailer should not be towed at speeds over 55 mph. The Wayside Solar unit on a trailer also requires the solar panels to be tied down the system before transport (see sec. 3.7.4)

3.7.2 Trailer Safety Information



Warning! – Keep hair, loose clothing, fingers, and all parts of the body away from openings and moving parts.

3.7.2.1 Tire Safety

1. Failure to follow proper procedures when mounting a tire on a wheel or rim can produce an explosion, which may result in severe injury or death.
2. Do not attempt to mount a tire unless you have the proper equipment and experience to do the job.
3. Inflating or servicing tires can be dangerous. Whenever possible, trained personnel should be called to service and/or mount tires.
4. Always order and install tires and wheels with appropriate capacity to meet or exceed the anticipated weight to be placed on the equipment.

3.7.2.2 Before Operation Safety



Before operating the winches on your unit trailer, check all clamps to guarantee they are tight for your safety. Failure to do this may result in bodily injury.

1. Carefully study and understand this manual.
2. Keep wheel lug nuts or bolts tightened to the specified torque.
3. Assure that tires are inflated to proper air pressure.
4. Give the unit a visual inspection for any loose bolts, worn parts, or cracked welds, and make necessary repairs. Follow the maintenance safety instructions in this manual.
5. Do not use the unit until you are sure that the area is clear.
6. Securely attach to towing unit. Use a high strength, proper-sized hitch ball with a mechanical retainer and attach a safety chain.
7. Do not allow anyone to stand between the tongue or hitch and the towing vehicle when backing up to the equipment.



Section 3 – Unit Operation

3.7 Trailer (Wayside 120V and Wayside Solar Only)

3.7.2.3 During Operation Safety

1. Children should not be allowed on the product.
2. Clear the area of small children and bystanders before moving the unit trailer.
3. Ensure you comply with all local and state regulations regarding transporting equipment on public roads and highways. Lights must be clean and visible by overtaking or oncoming traffic when the trailered unit is transported.
4. SAFETY CHAIN – If the equipment is transported on a public highway, a safety chain should be obtained and installed. Always follow state and local regulations regarding a safety chain and auxiliary lighting when towing your trailered unit on a public highway. Be sure to check with local law enforcement agencies for your particular regulations. Only a safety chain (not an elastic or nylon/plastic tow strap) should be used to retain the connection between the towing and towed machines in the event of separation of the primary attaching system.
5. Install the safety chain by crossing the chains under the tongue and secure to the drawbar cage, hitch, or bumper frame.
6. Beware of bystanders, particularly children! Always look around to ensure that it is safe to start the towing vehicle's engine or move the unit. This particularly important with higher noise levels and quiet cabs, as you may not hear people shouting.
7. NO PASSENGERS ALLOWED – Do not carry passengers anywhere on, or in, the frame, except as required for operation.
8. Keep hands and clothing clear of moving parts.
9. Do not clean, lubricate, or adjust your equipment while it is moving.
10. Be especially observant of the operating area and terrain – watch for holes, rocks, or other hidden hazards. Always inspect the site before operation.
 - DO NOT operate near the edge of drop-offs or banks.
 - DO NOT operate on steep slopes as overturn may result.
 - Operate up and down (not across) intermediate slopes. Avoid sudden starts and stops.



Section 3 – Unit Operation

3.7 Trailer (Wayside 120V and Wayside Solar Only)

3.7.2.4 Highway and Transportation Safety

1. DO NOT!! EXCEED 55 MILES PER HOUR
2. Adopt safe driving practices:
 - Always drive at a safe speed relative to local conditions and ensure that your speed is low enough for an emergency stop to be safe and secure. Keep speed to a minimum.
 - Reduce speed before turns to avoid the risk of overturning.
 - Avoid sudden uphill turns on steep slopes.
 - Do not drink and drive!
3. Comply with state and local laws governing highway safety and movement on public roads.
4. Local and state laws should be checked for all highway lighting and marking requirements.
5. Be a safe and courteous driver. Always yield to oncoming traffic in all situations, including narrow bridges, intersections, etc.
6. Be observant of bridge load ratings. Do not cross bridges rated lower than the gross weight as which you are operating.
7. Watch for obstructions overhead and to the side while transporting.
8. Always operate equipment in a position to provide maximum visibility at all times. Make allowances for increased length and weight of the equipment when making turns, stopping the unit, etc.
9. Be extra careful when working on inclines.
10. Avoid loose-fill, rocks, and holes; they can be dangerous for equipment operation or movement.
11. Operate the towing vehicle from the operator's seat only.
12. As a precaution, always recheck the hardware on equipment following every use—correct all problems. Follow maintenance safety procedures.

3.7.2.5 After Operation Safety

1. Store the unit in an area away from human activity.
2. Do not permit children to play on or around the stored unit.
3. Make sure all parked machines are on a hard, level surface, and engage all safety devices.
4. Wheel chocks may be needed to prevent the unit from rolling.



Section 3 – Unit Operation

3.7 Trailer (Wayside 120V and Wayside Solar Only)

3.7.3 Trailer Lowering/Crank Down Procedure



FAILURE TO FOLLOW THESE INSTRUCTIONS MAY CAUSE SERIOUS BODILY INJURY AND/OR DAMAGE TO THE UNIT/TRAILER.

Danger – Keep hands and feet clear of the trailer frame when lowering.

Danger – DO NOT lean over the leaf spring while raising or lowering the trailer; stand behind the winch.

The trailer can be lowered to the ground using the three cranks/winches. There is one crank/winch located behind each wheel as well as one behind the tongue jack. There are also leveling jacks at each corner of the trailer. Begin the process by setting the leveling jacks at the desired height for the trailer position once it has been lowered. Each leveling jack using a clevis pin with a locking cotter pin. Ensure all the locking cotter pins are in place on the leveling legs before lowering the unit.

Begin the lowering process at the front crank/winch located behind the tongue jack. The cotter pin and clevis pin must be removed first. The clevis pin might require the crank/winch to be raised slightly to relieve pressure from the clevis pin to more easily remove. Change back and forth between cranking up and down using the smaller lever on top of the winch. Ensure that the small winch lever has been placed in one of the locking positions (crank up or down position) before removing the clevis pin. The lever not fully pushed to one side allows the winch to spin freely. Doing so will prevent the unit from lowering on its own due to its own weight. Once the clevis pin has been removed, flip the small lever on the winch to allow the crank to be turned in the direction that will lower the trailer and crank down. The unit should be lowered until the front leveling legs come in contact with the ground. Follow the same procedure for each of the cranks/winches behind the wheels. The winches behind the wheels should be used alternating, lowering each a bit back and forth until the rear leveling legs are in contact with the ground. Raise the unit using this procedure in reverse. Raise the rear/wheel winches and install the pins before raising the front/trailer tongue winch.



Front/Tongue Winch



Rear Winch and Leveling Leg



Section 3 – Unit Operation

3.7 Trailer (Wayside 120V and Wayside Solar Only)

3.7.4 Solar Panel Tie Down (Trailer Solar Only)

The solar panels should be secured before any travel with the trailered unit. High winds can threaten the solar panel support structure under transport and should always be secured with the provided solar panel retaining cover and straps before any movement. The solar mesh cover attaches with a series of buckling straps across the short direction and two straps across the long direction. The shorter straps should encompass the long side straps, and all should be tightened as much as possible before moving to prevent cover flapping in the wind.



Solar Mesh Cover

The strap set provided should then be used to secure the cover to the trailer base. The front strap loop strap should be attached to the cover's loops and subsequently tied down with the ratcheting strap to the winch's cross-bar, as shown. The rear ratcheting straps can be distinguished from the front ratcheting due to their longer length. These straps should be attached to the solar mesh cover loops and then to the appropriate winch cross-bar. The ratcheting unit end of each strap should be attached to the winch cross-bar to keep the ratchet unit as low and out of the wind as possible. The tension set in the ratchets should not be excessive or significant damage to the solar rack may occur. The straps should be just tightened enough to tension the straps.



Front Solar Tie-Down Configuration



Rear Solar Tie-Down Configuration



Section 3 – Unit Operation

3.8 Battery Charging (Trailer Units Only)

While the Wayside and Outpost units both have batteries that need to be charged, the trailer version is the only one that the user has an active role in ensuring that the battery charge is maintained. The other versions of the units are either minded constantly by the solar charging system or are connected to grid power with a constant charge connection. The trailer unit must be kept with the batteries in a good state of charge to function correctly and ensure extended-lasting function. There is a load on the batteries as long as the main power shut-off switch is active and will drain the battery pack. If the unit is to sit for longer than one month without operation, see storage instructions (sec. 4.6).

3.8.1 Charging Procedure

1. Read all safety information in the following section before charging.
2. Make sure the unit is in a well-ventilated area.
3. Open the rear service door and locate the large red and black box mounted to the back wall straight inside the service door. The black box is the battery charger. It will have a power cord coming from the bottom of it.
4. Connect this AC supply cord to an appropriate outlet. Outlet requirements can be found in Section 2.1.2.2 – Power Supply.
5. The charger will start after a short delay, as indicated by the “spinning” light in the round display in the center of the charger. The appropriate % level indicator will also light up depending on the battery charge state when plugged in. The indicated “% LED” will increase as the charge progresses. The indicator light will be illuminated as long as the charge state is less than the displayed label. For example: when the “25% LED” is illuminated, it means the battery pack is below 25% state of charge. When it goes out and the “50% LED” turns on, it means the battery pack is below 50% state of charge but above 25%.
6. Once the charge is completed, the charger will automatically turn off, and the “100% LED” indicator will turn green. After the charger has turned off, disconnect the AC supply cord from the outlet.

***Note: The main power shut-off must be in the active/“on” position for the batteries to charge.**



Charger Indicator



Section 3 – Unit Operation

3.8 Battery Charging (Trailer Units Only)

3.8.2 Charger Safety Information



WARNING – TO REDUCE THE RISK OF FIRE, ELECTRIC SHOCK, OR INJURY:

1. AGM batteries can generate gases that can be explosive. Charge the batteries only in well-ventilated areas. Keep sparks, flame, and smoking materials away from batteries.
2. Only charge this unit with the appropriate battery charger that is supplied with the unit.
3. To reduce the risk of electrical shock, unplug the charger from a live outlet or disconnect AC power to the outlet before attempting any maintenance or cleaning.
4. Before charging, the state of connections and cables must be checked and tightened if necessary.
5. Charge the unit only in a room free of pollution and with sufficient ventilation.



WARNING: Improper connection of the equipment-grounding conductor can result in a risk of electric shock.

3.8.3 Extension Cord Requirements

Always use a three-conductor, No. 14 AWG heavy-duty cord with ground that is properly wired. The extension cord should be in good electrical condition and kept as short as possible. Ensure the pins on the extension cord's plug are the same number, size, and shape as the unit's AC plug. The use of an improper extension cord could result in the risk of fire or electrical shock. Place all cords so they will not be stepped on, tripped over, or otherwise subjected to damage or stress.

3.8.4 Partial Recharging

The charger is designed to adapt automatically to all battery discharge states and allows all types of partial charge cycles or "opportunity charging," meaning the unit can be charged at any time, no matter what the state of charge.

3.8.5 Charge Time

Charge time will vary depending on the depth of discharge, age, and temperature of the batteries. Allow up to 8 hours for full recharging.



Section 3 – Unit Operation

3.8 Battery Charging (Trailerred Wayside Units Only)

3.8.6 Battery Break-In

When the batteries are new, make sure to charge the battery pack before its first use. No special procedures are needed for seasoning the batteries other than just to use the unit and charge it regularly. New batteries are not capable of their rated output until they have been discharged several times. It generally takes 90-120 cycles to maximize battery capacity fully.

3.8.7 Depth of Discharge

Do not excessively discharge the batteries. Discharge below 20% state of charge can cause polarity reversal of individual cells resulting in complete failure shortly after that. The limited discharge depth of new batteries will also minimize the chance of cell reversal. Charge the batteries to their full state once a month, whether they are used or not, to ensure they will not fully discharge. Continually deeply discharging the batteries will also shorten their cycle life.



Section 4 – Maintenance and Care



ATTENTION! - Read all safety rules carefully before attempting to service. Failure to comply can result in accidents involving fire, electric shock, or serious personal injury.

****Important!** - Always disconnect power from the system using the main power shut-off switch before any type of service.

General Maintenance Safety Guidelines:

1. Be sure all moving parts on the unit have come to a complete stop before performing maintenance.
2. Always use the proper tools or equipment for the job at hand.
3. Never replace hex bolts with less than grade five bolts unless otherwise specified.
4. After servicing, be sure all tools, parts, and service equipment are removed.
5. Use extreme caution when making adjustments.
6. Where replacement parts are necessary for periodic maintenance and servicing, genuine factory replacement parts must be used to restore your equipment to its original specifications. The manufacturer will not claim responsibility for the use of unapproved parts and/or accessories and other damages resulting from their use.
7. If the equipment has been altered in any way from the original design, the manufacturer does not accept any liability for injury or warranty.

4.1 Vacuum System (Station/Wayside Only)

4.1.1 Tank Emptying

The vacuum collection tank will need to be emptied periodically. To do so, open the vacuum service door located on the right rear sloped roof panel of the unit. Insert the appropriate key into the lock cylinder and turn 90 degrees clockwise to release the door latch. Open the door and swing on the hinges entirely to rest on the upper roof panel. Take care in high wind situations that the door does not blow back closed unexpectedly, or personal injury may occur. Remove the blue pipe plug by turning it counterclockwise and removing it. The rubber ring around the plug should also be removed for clear access into the tank. Take care not to drop the rubber sealing ring into the tank port.

The tank should be evacuated using a septic pumping rig or something similar. It is recommended to use a long extension to the suction hose and agitate the tank's material as it is being removed or before removing it. Doing so prevents clumping at the bottom of the tank and enables complete tank evacuation.





Section 4 – Maintenance and Care

4.1 Vacuum System (Station/Wayside Only)

4.1.2 Vacuum Pressure Relief Valve

The vacuum tank is equipped with a pressure relief valve to regulate the amount of tank vacuum that can be attained in a blocked hose scenario. Doing so keeps the motor from being harmed from surging due to lack of airflow. For this reason, it is essential to monitor the function of this valve and maintain the proper setting. The valve should be set so that the vacuum hose has wholly blocked the valve, and it actuates just as the vacuum motor begins to surge. (See also maintenance schedule - sec. 4.9)

The valve is adjusted with a set nut on the threaded spindle sticking up from it. Turning the nut clockwise will make it open at a later/higher tank vacuum point. Turning the nut counterclockwise will cause the valve to open at a sooner/lower tank vacuum point. The second nut is to lock the position of the bottom nut in place.



4.1.3 Inspect Hose

The vacuum hose should be checked regularly for cracks, breakage, clogs, or other damage. The performance of the vacuum system is heavily dependent on the hose condition. While it is a robust hose, it is very vulnerable to damage due to its size and inherent user disregard for its well-being. (See also maintenance schedule - sec. 4.9)



Section 4 – Maintenance and Care

4.2 Blower/Compressor (Station/Wayside Only)

4.2.1 Blower/Compressor Maintenance Safety



****Important! - Always disconnect power from the system using the main power shut-off switch and relieve all air pressure from the system before servicing.**

TO REDUCE THE RISK OF FIRE, ELECTRIC SHOCK, OR INJURY WHILE SERVICING:

1. The air produced by this unit is not fit for human or animal consumption, and it must not be used to provide a breathing air supply.
2. The compressor is designed for use in the compression of normal atmospheric air only. No other gases, vapors, or fumes should be exposed to the compressor intake nor processed through the compressor.
3. Make sure to disconnect all power supplies to the unit before any service on the compressor/blower system.
4. Relieve all pressure internal to the compressor or blower system before servicing. Do not depend on any check valves to hold system pressure.
5. Do not change the pressure setting on the safety relief valve, restrict the safety relief valve's function, or replace the safety relief with a plug. Over pressurization of some system or compressor components can occur, resulting in severe personal injury, death, and property damage.
6. Do not modify the system to dispense air at any pressure exceeding 90 PSI.
7. Never use flammable or toxic solvents for cleaning the air filter or any parts.
8. Do not attempt to service any part while the compressor is operating.
9. Do not operate the compressor at any pressure above its rating.
10. Do not operate with the shrouds or belt guard removed.
11. Follow all maintenance procedures and check all safety devices on a schedule.
12. Use the correct lubricants at all times.
13. The pump and manifold generate high temperatures. To prevent burns or other injuries, do not touch the pump, manifold, or transfer tube while the pump is running. Allow them to cool before handling or servicing.
14. Keep children away from the compressor at all times.
15. Always wear hearing protection when using an air compressor. Failure to do so may result in hearing loss.



Section 4 – Maintenance and Care

4.2 Blower/Compressor (Station/Wayside Only)

4.2.2 Air Pressure Regulator

The air pressure regulator can be found attached to the inside of the unit frame near the hose exit location. This location is to the right side when accessing from the rear service door. The air pressure regulator ensures that the air dispensed through the blowgun is at a consistent and metered pressure of 90 psi at a maximum. The dispensing pressure needs to be checked while the blowgun is dispensing air. The pressure at the gauge will show slightly higher while the blowgun is not being operated. This setting should be monitored for correctness because an incorrect pressure at the regulator could be a symptom of another issue somewhere in the system. The pressure can be adjusted by pulling up on the round black cap at the top of the regulator and rotating it clockwise to increase pressure and counter-clockwise to decrease it. Warning! - Do not modify the system to dispense air at any pressure exceeding 90 PSI.



4.2.3 Relief Valve

The relief valve can be found at the compressor's front at the top, center of the tank on the Station. It can be found at the top of the compressor sticking out the four-way fitting side coming out of the top of the compressor on the Wayside units. Pull the relief valve regularly to ensure that it is operating correctly and clear the valve of any possible obstructions. (See also maintenance schedule - sec. 4.9)



Station



Wayside



Section 4 – Maintenance and Care

4.2 Blower/Compressor (Station/Wayside Only)

4.2.4 Air Filter

A dirty air filter will reduce the compressor's performance and life and cause the compressor to pump oil. The filter should be replaced regularly to avoid any internal contamination of the compressor pump. Do not allow the filters to become filled with dirt. (See also maintenance schedule - sec. 4.9)



Station



Wayside

4.2.5 Air Leaks

Check that all connections in the air system are tight regularly. A small leak in any of the hoses, transfer tubes, or pipe connections will substantially reduce the air compressor's performance. If you suspect a leak, spray a small amount of soapy water around the areas with a spray bottle. If bubbles appear, reseal and retighten the connection. Do not over-tighten. (See also maintenance schedule - sec. 4.9)



Section 4 – Maintenance and Care

4.2 Blower/Compressor (Station/Wayside Only)

4.2.6 Compressor Oil

4.2.6.1 Station Compressor

The oil level should be checked regularly. The sight glasses can be found in front of the compressor base on the Station. The level should be maintained at about $\frac{1}{4}$ " above the center of the sight glass with 30-weight quality non-detergent air compressor oil only. Do not overfill. The original break-in oil should be changed at 8 hours of operation. For operating temperatures below 30 degrees Fahrenheit, use ten weight air compressor oil. (See also maintenance schedule - sec. 4.9)

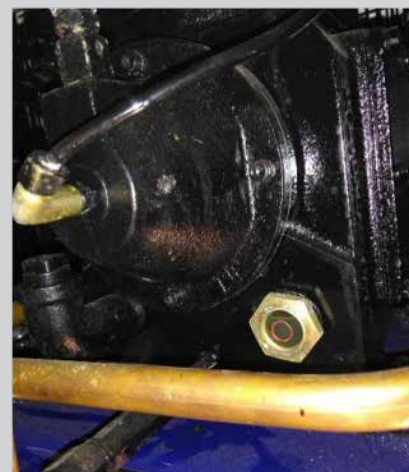

4.2.6.2 Wayside Compressor

The oil level should be checked regularly. The sight glass can be found in front of the compressor base unit. If no oil is visible in the window, remove the oil plug from the compressor's side and add oil until it is visible. The level should be maintained, as shown in the graphic to the right. Use full synthetic 30 weight air compressor oil only. Do not overfill. (See also maintenance schedule - sec. 4.9)

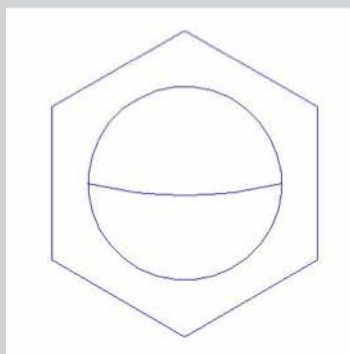

4.2.7 Compressor Belts (Station Only)

The oil level should be checked regularly. The sight glass can be found in front of the compressor base unit. If no oil is visible in the window, remove the oil plug from the compressor's side and add oil until it is visible. The level should be maintained, as shown in the graphic to the right. Use full synthetic 30 weight air compressor oil only. Do not overfill. (See also maintenance schedule - sec. 4.9)

Warning! – make sure that power is disconnected from the equipment before belt guard removal. Do not operate the compressor with the belt guard removed.

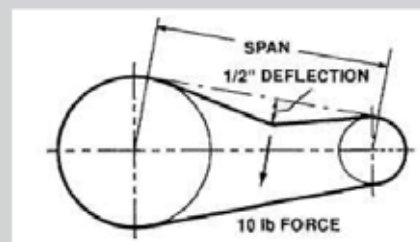



Section 4 – Maintenance and Care

4.3 Tool Reels

4.3.1 Reel Lubrication

The tool reels are factory lubricated for life. No additional lubrication is required.

4.3.3 Tension Adjustment

Danger! - Never add/release tension when the cable is extended from the reel. The cable must always be fully wound on the reel.

Danger! - DO NOT allow the cable to retract in an uncontrolled manner. Always guide cable back to reel. Failure to do so can result in damage to the reel or personal injury.

Tension adjustment procedure:

1. Hold the shaft securely with a wrench and remove the two screws from the hub.
2. Turn the shaft clockwise/counter-clockwise to add/release tension (one full turn at a time).
3. When the desired tension is achieved, replace the two screws.

4.3.4 Spring Replacement

Danger! - DO NOT attempt to remove the spring motor from its canister. Doing so can result in damage to the reel or personal injury.

Spring motors are self-contained for safe and easy handling. If a spring motor replacement is required, it should be replaced as a unit by ordering a spring motor kit containing the spring motor, spool, shaft, and bushings in a sealed canister.

4.3.5 Reel Sensors

Each tool reels are equipped with a proximity sensor that indicates when the tool is at its home position or not. The home position is when the tool cable is fully retracted, and the tool is hanging at the unit. The sensor is mounted on the cable reel just inside the unit's front face and reads a small metal collar attached to the cable just behind the cable stopper on the cable itself. The sensor is not active when the tool is in its home position and is actively pulled from the home position. The reel sensor is adjustable with two locking nuts on the body and can be adjusted for proper collar reading. The sensors also depend on the tool reel return spring retracting the cable to bring the sensor to the home position. If this spring is not achieving this task, the tension can be adjusted to compensate (see 4.3.3 Tension Adjustment)

4.3.6 Tool Replacement

The tool replacement is intended to cut and remove the intermediate loop in the tool cable. The small loop connecting the tool is to keep the cable into the cable reel from being changed. Doing so keeps the stopper and sensor positions on the cable more consistent.





Section 4 – Maintenance and Care

4.4 Batteries (Wayside/Outpost Only)



Batteries can produce explosive gases. Therefore, do not allow sparks or flames to come near the batteries. When working near the batteries, always shield your face and protect your eyes. Always provide ventilation.

Whenever cleaning or servicing the batteries, be sure to disconnect power at the main power shut-off switch.

4.4.1 Battery Safety Precautions

Always observe the following personal safety precautions when working with lead-acid batteries:

1. Remove all current load from batteries before servicing in any way. Doing so can be achieved by turning off the main power shut-off switch.
2. Someone should be within the range of your voice or close enough to come to your aid when you work near a battery.
3. Keep batteries out of the reach of children.
4. Always only connect the positive (+) cable to the positive terminal and the negative (-) cable to the negative terminal. Reversing polarity is very dangerous.
5. Never smoke or allow a spark or flame in the vicinity of the batteries.
6. Be extra cautious about reducing the risk of dropping a metal tool onto the battery. It might spark or short-circuit the battery or other electrical parts that may cause an explosion.
7. Remove personal metal items such as rings, bracelets, necklaces, and watches when working with a battery. A lead-acid battery can produce a short-circuit current high enough to weld a piece of jewelry such as a ring to another metal, causing a severe burn.
8. Never charge a frozen battery.
9. Do not lift a battery by the terminal posts, or internal damage may result.



Section 4 – Maintenance and Care

4.4 Batteries (Wayside/Outpost Only)

4.4.2 Battery Pack Inspection

Warning! - Make sure power has been disconnected from the batteries before the inspection process. *Note: The main battery shut-off does not remove power from the batteries. It only can shut off battery power to the unit and stop current draw from them. The batteries themselves will always still have energy in them.

4.4.2.1 Access

The Outpost unit will have the batteries right in front of the service door. The Wayside 120V and Wayside Solar will have the batteries visible to the unit's right side when accessed from the service door. The batteries are visible through the door, but the rear panel will have to be removed for further clear access. First, remove the door by swinging it all the way open and lifting it off the hinges. Then, remove the three screws inside the door jam of the panel. Swing the panel out slightly and pull it away from the unit. There are only tabs holding it in place on the opposite side.

4.4.2.2 What To Look For

Inspect for any loose connections by wiggling the top post battery cables attached to the top of the battery. If you find any signs of a loose cable connection, they must be tightened by a trained professional before the main power shut-off switch is turned back on. Inspect for any acid spills or corrosion to the battery posts or cables. If corrosion exists, the aluminum or metal components will turn white. All acid and vulnerable metals must be cleaned appropriately by a trained professional before the main power shut-off switch is turned back on. Reassemble all removed components to the unit before turning the main power shut-off switch back on.

4.4.3 Battery Cleaning

Keep the top of the batteries clean and dry to ensure long-lasting, trouble-free operation. Also, make sure the battery cables are always tightly fastened to the battery terminals. Make sure the cables are tight to the terminals but be careful not to overtighten. Any corrosion present on the batteries or terminals should be cleaned promptly by brushing them off with a wire brush. The acid can be neutralized with a solution of baking soda and water.

4.4.4 Battery Disposal

Always responsibly dispose of batteries. Follow your local standards for disposal. Contact your local authorized recycling center to find out more about recycling batteries.



Section 4 – Maintenance and Care

4.5 Fuses

The fuses are only present on the Wayside and can be found just inside the service door above the batteries. The Wayside unit has the fuses under a cover on the main positive post coming off the battery pack's left side. The Outpost unit has a single automotive-style fuse located on the electrical component plate just above the battery pack and below the solar charger. Replace only with fuses of the same style and power rating.

*Note: The Station unit also contains fuses and circuit breakers within the electrical box that a professional should only service. Contact a qualified CD3 service person.



Wayside

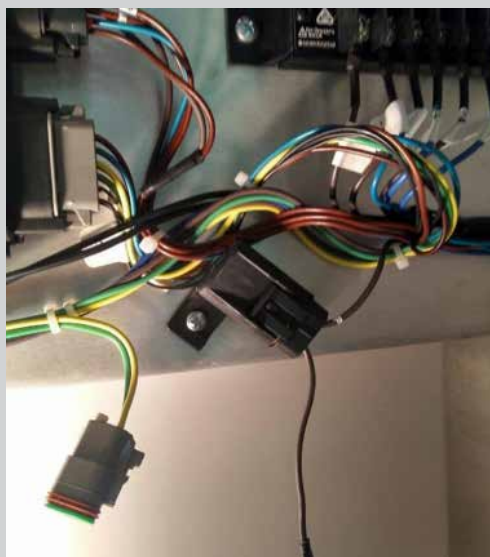

Outpost



Section 4 – Maintenance and Care

4.6 Trailer (Wayside120V and Wayside Solar Units Only)



****Important! - Always use a safety support and block the wheels when working under the trailer. Never use a jack alone to support the trailer.**

4.6.1 Greasing Wheel Bearings

The trailer wheel bearings are unlike those in your motor vehicle in that they require periodic maintenance to ensure reliable, safe operation. They should be greased on a maintenance schedule following the table in section 4.9 Maintenance Schedule Table. The procedure is given below, but always begin by jacking the trailer up and supporting it with appropriate jack stands for added safety.

Disassembly

1. Lift and support trailer with the subject wheel free of ground contact. Place jack stands on the trailer frame relatively near the subject wheel.
2. Remove the wheel.
3. Remove the hub dust cap by gently prying it from the hub.
4. The cotter pin will need to be removed, which will allow the removal of the castle nut along with the spacer washer, outer wheel bearing, and hub.
5. The backside of the hub houses the inner wheel bearing. The bearing seal is pressed into the hub's back and needs to be removed to get the inner wheel bearing out. A puller should be used to remove the seal without causing damage.
6. Before repacking bearings, all grease must be removed from the hub/drum and bearings. Bearings should be packed by machine or hand methods to ensure that grease is forced into the cavities between the rollers, cone, and cage of the bearings.
7. Use a high temperature, automotive type wheel bearing grease to repack your bearings. Once bearings are adequately greased, you are now ready to reassemble the hub to the axle.

Assembly

1. Re-assemble the hub and brake assembly in the reverse order that it was disassembled.
2. When installing the bearings back into the hub, be sure to fully grease the bearings themselves, the bearing races, and the spindle shaft.
3. Slowly spin the hub on the spindle while tightening the spindle nut to 50 ft-lbs. Once the finish torque is reached, stop turning the hub. Loosen the spindle nut without turning the hub—torque the spindle nut to 25 in-lbs. (Note: torque spec is in Inch pounds, not foot-pounds). If the hole in the spindle lines up with a castellation in the nut, then install the cotter pin and bend the ends apart. If the hole does not line up, continue to torque the nut until the hole lines up with the next castellation – Spindle nut torque should not exceed 45 in-lbs. (Note: torque spec is in Inch pounds, not foot-pounds). Then insert the cotter pin and bend the ends apart.
4. Re-torque the wheel lug nuts to 100 ft-lbs in an alternating crisscross pattern.

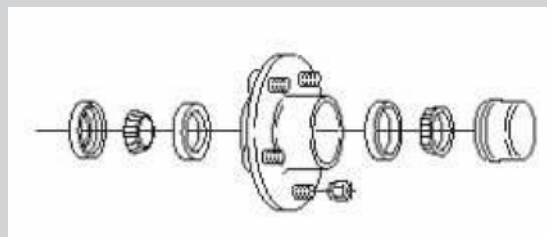



Section 4 – Maintenance and Care

4.6 Trailer (Wayside120V and Wayside Solar Units Only)

4.6.2 Tire Pressure

Under-inflation increases tire flexing and can result in tire failure. Over-inflation causes a tire to be too stiff, making it more vulnerable to puncture from objects on the ground. Unequal tire pressure can cause instability. All of these conditions can lead to uneven tire wear. Take these steps to ensure correct tire pressures:

- a. Use an accurate tire pressure gauge.
- b. Check the tire pressure when tires are cold after the trailer has been parked for over an hour or has been towed less than 2 miles.
- c. Adjust the tire pressure according to the recommended specifications listed on the sidewall of the tires.

4.6.3 Lift System Inspection

The lift system should be visually inspected before raising and/or lowering the trailer body. The inspection should look for anything that could infringe on the safe operation of the system. Check for any frayed or misaligned cables or appearance of wear in any area not appropriate. Excessive corrosion or damage to any component in the system could create a dangerous situation during use.



Section 4 – Maintenance and Care

4.7 Storage/Winterization

4.7.1 Cover

A cover for the unit's body is available from CD3 and is recommended for any long-term storage duration (such as winterization) to protect the unit's exterior finish. Doing so helps limit the decals' exposure to the elements and contains the tools to minimize undesired tampering in the off season. Unique covers are available for the Outpost, Station/Wayside, and Wayside Solar.

The cover installs by placing it over the unit and zipping it closed to the base. The base then has a ratcheting strap to pull the base tight. The strap should be threaded through the ratchet, pulled tight, and then tightened with the ratchet. The ratchet should be aligned under its cover flap and then covered by the flap.

4.7.2 Compressor in Storage (Station/Wayside Only)

Before storing the compressor for a prolonged period, shut off the main power shut-off switch. Remove all the pressure from the system. For the station, this includes pulling the pressure relief valve to release all pressure from the receiver. Drain all moisture from the receiver. Clean the filter housing: replace the elements if necessary. Drain the oil from the compressor pump crankcase, replace it with new oil, and briefly run the unit.



Section 4 – Maintenance and Care

4.7 Storage/Winterization

4.7.3 Batteries in Storage (Wayside/Outpost Only)

Warning! - Do not leave the unit for any length of time with discharged batteries. The batteries can be discharged to the point where damage will occur, and the battery charger will not charge them. To prepare the batteries for storage for a prolonged period (such as winterization), make sure that the batteries are fully charged and then shut off the main power shut-off switch. Doing so prevents any phantom power drains on the system. The batteries will continue to self-discharge over time, so it is recommended that the unit is charged if the duration of storage is longer than about eight months. The main battery disconnect must be turned back on to charge the unit. Make sure the unit is fully charged again before use.

To fully charge the unit before disconnect:

Wayside 120V – Plug the unit in (or leave it plugged in if it is operated this way) without using any of the functions and let stand until the green “100%” indicator illuminates – see 3.7.1 Charging Procedure)

Wayside Solar/Outpost – Leave the unit with the solar panels in as much sun as possible and discontinue use of the unit functions for a length of time to allow the batteries to charge. The batteries' status can be checked by opening the service door in the back of the unit and finding the solar charge controller (shown below). The solar charger will be straight inside the service door. The indicated set of lights will display the battery state of charge.



Outpost



Wayside Solar



Section 4 – Maintenance and Care

4.8 Care and Cleaning

You can use any mild cleaning soap or cleaner and soft towel for the entire unit exterior to clean the unit. A soft clean towel is suggested to avoid surface scratches and water spotting.

Caution: Do not spray water into the interior of the unit. Direct water on the electrical components or compressor could result in damage.

4.9 Key Replacement

To obtain an extra or replacement key for your unit, please call the CD3 Customer Assistance Center at 612-467-9441



Section 4 – Maintenance and Care

4.9 Maintenance Schedule Table

Task

Interval

	Daily	Weekly	Monthly	Yearly	50 hrs of Operation	Every 3 Mo or 300 hrs Operation
Compressor						
Inspect Hose		X				
Check Oil Level - Station	X					
Check Oil Level - Wayside					X	
Inspect Air Filter - Station		X				
Replace Air Filter - Wayside				X		
Clean Compressor		X				
Test Compressor Safety Valve			X			
Check V-belts - Station			X			
General Overall Inspection			X			
Oil Change - Station						X
Test for Air Leaks						X
Vacuum						
Inspect Hose		X				
Check Relief Valve			X			
Tool Reels						
Cable Inspection			X			
Trailer						
Check Tire Pressure and Lugs	X					
Grease Wheels Bearings			X			
Grease Hinge Points			X			



Section 5 – Theory of Operation

5.1 Control System

Each of the units is equipped with a system that allows the data to be collected and broadcast to a web source. This system also controls the function of the unit from the button inputs of the user. It also allows the proper functions to work in accordance with the associated inputs.

5.1.1 Control Module

This component is what operates all of the “smart” functions of the unit. The buttons feed to inputs in this module, and all the action outputs come from this module. It will also convey system function indications and fault codes through button blinking sequences (refer to Sec. 3 for specific indications). It operates on 24VDC power provided through the main electrical box on a Station and the main battery 30A fuse on a Wayside. This component is a black box with two plugs on it and can be found on the main electrical panel.

5.1.2 Cellular Gateway

This component takes the information from the control module and broadcasts it via a cellular connection. This component operates from 24VDC powered through the control module and can be found on the main electrical panel positioned above the control module. Four LED indicators that convey the different modes of operation of the unit are explained in the following sections.





HOW TO USE OUR DIAGNOSTIC PLATFORM

Powered by  **PARTFUL**
Explos. Click. Buy. Fix. In Seconds.





1. Log in to access our platform

Access the CD3 Systems platform using the following link - cd3systems.svt-app.com. Using your user credentials, sign in and access the technical procedures and content.

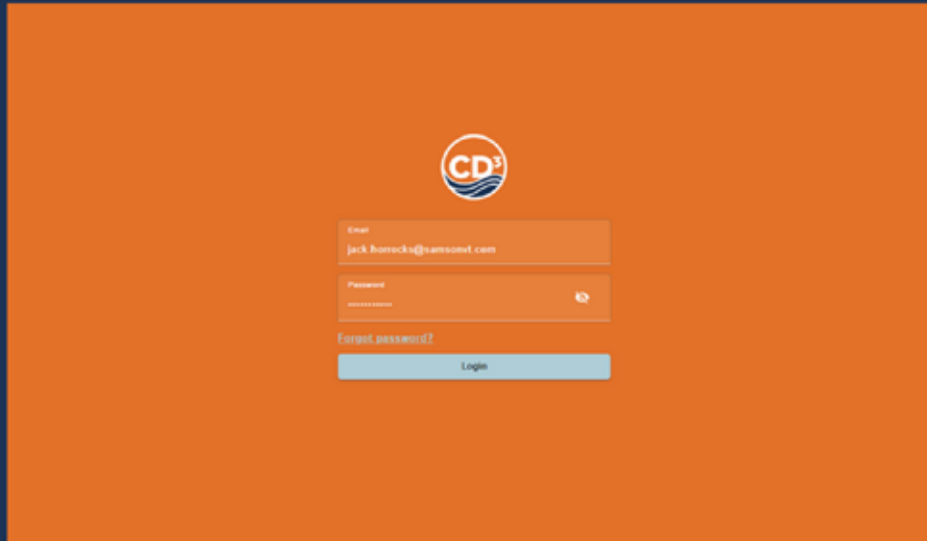

You can find your log in credentials in the invite email in your email inbox sent to you from hello@cd3systems.svt-app.com. The email subject line is "Invitation to join CD3systems".

If you have not logged in before, the password provided to you in the above email is a temporary one. Click "Activate account" in your email, use the temporary password and you will be required to set your actual password afterwards. If you have any issues logging in or cannot find the email, please contact our team at Stopais@cd3systems.com and we'll be on hand to help.

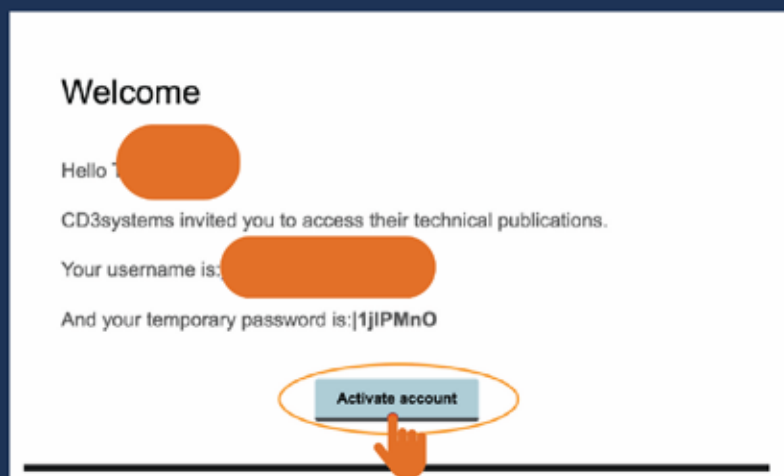



2. Diagnose the issue you are having

Find and select the product/model you own and are having issues with, the platform will load up the model.



Next step is define the problem you are having with the product. Select the problem you are experiencing to begin viewing the procedures to solve your problem.





Follow the diagnostic procedures that are listed, in order, by clicking "Next step" on the bottom right of the screen.

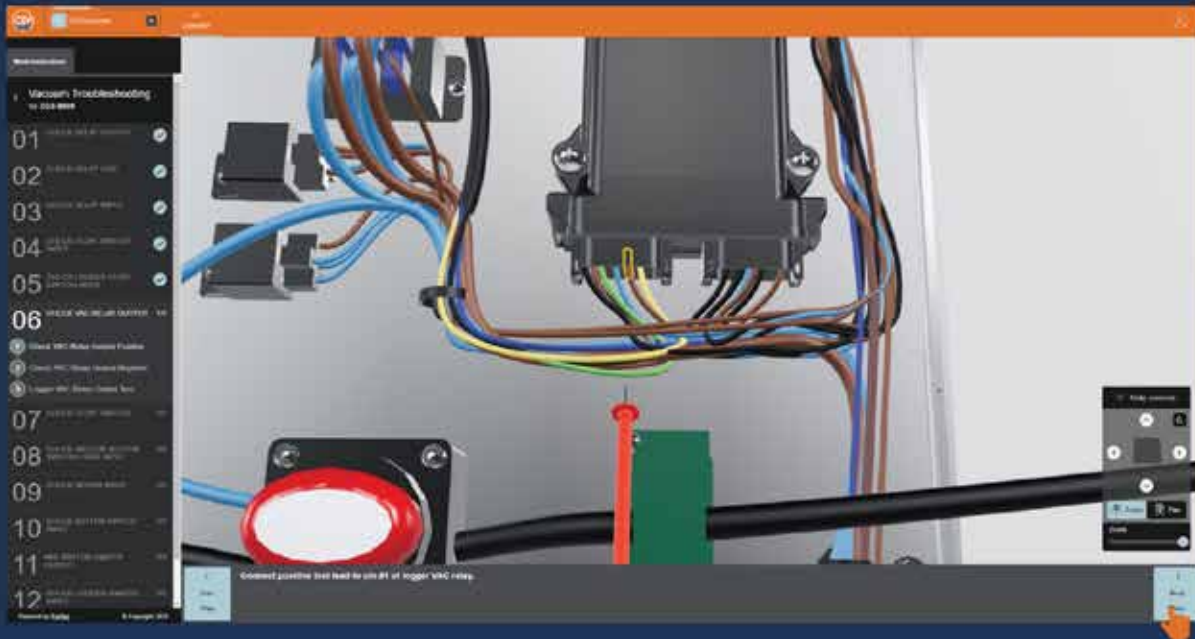

Please make sure each action is performed accurately according to the technical specifications so that the problem can be resolved.

By following the documented procedures, you will be able to identify the component(s) which are broken or responsible for issues within the machine's operational capabilities.

Then, contact us at Stopais@cd3systems.com regarding the broken component, and the replacement and refitting process for a new component.



Section 5 – Theory of Operation

5.1 Control System

5.1.2.1 Status LED Modes of Operation

	Color	Blink Type	Status
●	Magenta	Solid	Boot loader started loading Linux
●	Blue	Solid	Connected to portal through any connection type. If WIFI and CELL are not blue then this means connected to portal through Ethernet
●	Blue	Heartbeat	Normal heartbeat, running but not connected to portal through any connection type
●	Green	Flash	Programming SPU packet Programming (Downloader)
●	Green	Solid	Completed programming through SPU Programming completed (Downloader)
●	Yellow	Flash	Waiting for interlocks Waiting for required modules or Package Managers
●	Yellow	Solid	SPU Package Download in progress
●	Red	Flash	User intervention required
●	Red	Solid	Hard errors Programming failed (Downloader)



Section 5 – Theory of Operation

5.1 Control System

5.1.2.2 Wi-Fi LED Modes of Operation

	Color	Trigger Type	WIFI
●	Blue	Solid	Connected to portal through WIFI
●	Green	Solid	Network manager reports the WIFI Client is connected to an access point and has an IP address
●	Yellow	Flash	WIFI connected no internet (Ping 1.1.1.1 ping-i <interface name> WIFI connected without IP address
●	Yellow	Solid	WIFI enabled but no access point within range
●	Red	Flash	WIFI client not detected
●	Red	Solid	WIFI not configured Means no mlano exists (no hardware)

5.1.2.3 GPS LED Modes of Operation







	Color	Trigger Type	GPS
●	Green	Solid	Focused=4 or more satellites, error calculation is less than 200 meters, and mode=3 or more (at least 3D) XYZ
●	Yellow	Flash	Focused=4 or more satellites, error calculation is less than 200 meters, and mode=2 or more (at least 2D)
●	Yellow	Solid	Lock but high error No Lock
●	Red	Flash	GPS not present



Section 5 – Theory of Operation

5.1 Control System

5.1.2.4 Cell LED Modes of Operation

	Color	Blink Type	CELL
	Blue	Solid	Connected to portal through CELL
	Green	Solid	Modem manager reports the bearer is connected. (a bearer is a set of network connection settings for a cell carrier). This means the cell is connected to a data connection.
	Yellow	Flash	Modem Manager reports that the bearer is not connected cell signal is >10%. Modem Manager reports that the bearer is connected and cell signal is <=10%.
	Yellow	Solid	Modem Manager reports that the bearer is not connected and cell signal is <=10%.
	Red	Flash	Cell modem is not present
	Red	Solid	Cell not configured (Profiles but none set to auto connect) SIM card is not inserted in the module



Section 5 – Theory of Operation

5.2 Station

The power input is provided by the 230VAC 30A outlet and is directly supplied to the main electrical box. This box houses all breakers for each circuit and the main power disconnect switch on its front.

5.2.1 Compressor

The compressor operates directly from the 230VAC power and is supplied directly via a breaker to the compressor motor starter box. From there, the pressure switch turns on the compressor as needed based on tank pressure. The air is dispensed through the air hose, restricted by an air solenoid valve, allowing air to reach the blowgun when the appropriate function button is activated. The control module controls the programming for the timer and button light indications.

5.2.2 Vacuum

The power to the vacuum motor operates on 230V AC power from the main electrical box via a breaker within the box. The vacuum is actuated based on an output signal from the control module based on input from the appropriate lighted button. There is also a float switch inside the top of the vacuum tank that stops its function if it is full.

5.2.3 Lights

The lights operate on 12VDC power from the main electrical box. The signal from the button is also a 24VDC signal communicated to the main electrical box and then translated to the needed 12VDC coming out.



Section 5 – Theory of Operation

5.3 Wayside (Solar and 120V)

The Wayside units are both powered by a 24VDC battery pack that powers the system directly. The difference between the Wayside Solar and 120V units is how the battery pack is charged. The functionality of the two types of Wayside units is very similar, apart from the battery charging.

5.3.1 Battery Pack

The battery pack is common to both Wayside (Solar and 120V) units and comprises two 12V batteries connected in series to produce 24VDC that powers the Wayside units. The pack fully powers the unit and is discharged most heavily by the compressor drawing approximately 20A and the vacuum motor drawing around 10A. The pack will have a steady draw even when tools are not activated due to the button's lights, the control module being active, and the cellular gateway being active. The main disconnect switch will turn off all power draw from the battery pack. The charging that occurs on the pack varies depending on the type of charger (solar system or 120V charger). The pack is a nominal voltage of 24V (when tested as a pack - across the positive of one to the other's negative terminal). The fully depleted or 0% state of charge voltage is 21V, and the maximum is 29V.

5.3.2 Solar Panels/Solar Charging

The 120V unit uses the power input provided by the 120VAC 15A outlet (Wayside 120V only), which uses a smart charger to charge the battery pack. This feature can also be included with a Wayside Solar unit as an optional add-on. This charger is a direct 24V charger that uses a specific charge algorithm for the batteries provided. Any change in battery type would require a compatibility check with the charge algorithm setting. The charger will automatically turn on when it is plugged into AC power. The main power disconnect switch must be active to charge the batteries.

5.3.4 Compressor

The compressor operates directly from the batteries' 24VDC power through a 175A fuse, found on the primary power connection on the positive terminal of one battery. However, the pressure switch activates the compressor, which is powered with 24VDC through a relay on the main electrical panel. The compressor is an on-demand operation and only runs when the button has been activated. The compressor pressurizes the hose's air until it is dispensed from the blowgun when the trigger is pulled. The compressor will continue to run as needed based on air demand as long as the button remains activated. The programming ultimately dictates the compressor's operation for the timer and button light indications from the electrical panel's control module.



Section 5 – Theory of Operation

5.3 Wayside (Solar and 120V)

5.3.5 Vacuum

The vacuum motor operates on 24VDC power, sent from a relay on the main electrical panel. This relay is actuated by an output from the control module and dictated by the programming and associated lighted button input. There is also a float switch inside the top of the vacuum tank that stops its function if it is full.

5.3.6 Lights

The lights operate on 12VDC power from a relay on the main electrical panel. The signal from the associated lighted button is 24VDC but supplied in 12V to the relay.



Section 5 – Theory of Operation

5.4 Outpost

5.4.1 Battery Pack

The Outpost system is powered by a 24VDC battery pack that powers the system directly, and the power is supplied to the system through the solar panels is 24VDC as well. The panels are 12VDC output individually but wired in series to obtain the desired voltage. The panels charge the system through the solar charger, found on the main electrical panel inside the unit.

5.4.2 Solar Panels/Solar Charging

The Outpost unit utilizes solar panels to provide a charge voltage as long as they have the light provided. The panels themselves operate in the range of 12V and are wired in series to increase their collective voltage output to match the system. The amount of light and shade on the panels is critical in that if there is one entire cell of one panel covered or shaded, neither panel will not output power. The panels charge the battery pack through the solar charge controller, which is a buck type charger. The solar charge controller will only charge the battery pack as long as the voltage input from the panels is higher than the battery pack voltage.

5.4.3 Light

The light operates on 24VDC power from a relay bound to the wiring harness below the electrical panel. The signal from the associated lighted button is also 24VDC.



Section 6 – Digital Tools

6.1 Web Resources

A downloadable PDF user manual, equipment fix videos, and other FAQ's on equipment maintenance are located at:

<https://www.cd3systems.com/OWNER-PORTAL/>



Section 7 – Customer Assistance Information

Customer satisfaction is a primary goal of CD3. If you have any questions or concerns with your CD3 unit, please contact the CD3 Customer Assistance Center.

By Phone: **612-467-9441**

Hours of operation: **Monday through Friday CST, 8am to 5pm**

By e-mail **StopAIS@CD3systems.com**

When contacting the Customer Assistance Center, please have the following information available:

- The unit identification number (serial)
- The model type of your unit



Section 8 – Warranty Statement

Terms and Conditions

1. Applicability.

These Terms and Conditions including the terms on the reverse side ("Agreement" or "Terms") are the only terms that govern the sale of the CD3 Unit(s) and related components ("CD3 Unit(s)") by CD3, General Benefit Corporation ("Seller") to the Buyer named on the reverse side ("Buyer"). These Terms prevail over any terms and conditions of purchase submitted by Buyer.

2. Shipping Terms & Taxes.

- a. Seller will deliver the CD3 Unit(s) FCA Seller's facility in Princeton, Minnesota (INCOTERMS 2010) (the "Delivery Point") using Seller's standard methods for packaging and shipping such CD3 Unit(s). The cost of shipping and insurance (if requested by Buyer) will be prepaid by Seller and added to the invoice.
- b. The Price does not include shipping charges, related insurance costs and taxes. Seller will estimate shipping, insurance and taxes on the reverse side; however, Buyer shall be responsible for all such charges, costs and taxes regardless of such estimate.
- c. The CD3 Unit(s) will be delivered within a reasonable time after the date of this Agreement. Seller shall not be liable for any delays, loss or damage in transit.

3. Title and Risk of Loss.

Title and risk of loss of the passes to Buyer upon delivery of the CD3 Unit(s) at the Delivery Point. As collateral security for the payment of the purchase price of the CD3 Unit(s), Buyer hereby grants to Seller a lien on and security interest in and to all of the right, title and interest of Buyer in, to and under the CD3 Unit(s), wherever located, and whether now existing or hereafter arising or acquired from time to time, and in all accessions thereto and replacements or modifications thereof, as well as all proceeds (including insurance proceeds) of the foregoing. The security interest granted under this provision constitutes a purchase money security interest under the Minnesota Uniform Commercial Code.

4. Inspection and Rejection of Nonconforming CD3 Unit(s).

- a. Buyer shall inspect the CD3 Unit(s) within two business days of receipt by Buyer ("Inspection Period"). Buyer will be deemed to have accepted the CD3 Unit(s) unless it notifies Seller in writing of any Nonconforming CD3 Unit(s) during the Inspection Period and furnishes such written evidence or other documentation as required by Seller. "Nonconforming CD3 Unit(s)" means only the following: product shipped is materially different than identified in this Agreement.
- b. If Buyer timely notifies Seller of any Nonconforming CD3 Unit(s), Buyer shall give Seller written notice stating in reasonable detail why the CD3 Unit(s) is Nonconforming. If Seller agrees with such determination, Seller shall have a reasonable amount of time from the receipt of such notice to fix or otherwise make such CD3 Unit(s) conforming.
- c. Buyer acknowledges and agrees that the remedies set forth in Section 4(b) are Buyer's exclusive remedies for the delivery of Nonconforming CD3 Unit(s). Except as provided under Section 4(b), Buyer has no right to return any CD3 Unit(s) purchased under this Agreement to Seller.

5. Price.

Buyer will purchase the CD3 Unit(s) at the price (the "Price") set forth in this Agreement.



Section 8 – Warranty Statement

6. Payment.

- a. Buyer will pay interest on all late payments at the lesser of the rate of 1.5% per month or the highest rate permissible under applicable law, calculated daily and compounded monthly. Buyer will reimburse Seller for all costs incurred in collecting any late payments, including, without limitation, attorneys' fees.
- b. Buyer will not withhold payment of any amounts due and payable by reason of any set-off of any claim or dispute with Seller, whether relating to Seller's breach, bankruptcy or otherwise.

7. Buyer Representations and Warranties.

Buyer represents and warrants to Seller that it has the full right, power and authority to enter into this Agreement and to perform its obligations under this Agreement. Buyer also represents and warrants that the execution of this Agreement by its representative whose signature is on this Agreement has been duly authorized by all necessary action of the Buyer.

8. Limited Warranty.

The Buyer agrees to the terms of the Limited Warranty set forth in Exhibit A attached to this Agreement.

9. Limitation of Liability.

IN NO EVENT SHALL SELLER BE LIABLE FOR ANY CONSEQUENTIAL, INDIRECT, INCIDENTAL, SPECIAL, EXEMPLARY, PUNITIVE, OR ENHANCED DAMAGES, LOST PROFITS OR REVENUES OR DIMINUTION IN VALUE, ARISING OUT OF, OR RELATING TO, OR IN CONNECTION WITH ANY BREACH OF THIS AGREEMENT, REGARDLESS (A) WHETHER SUCH DAMAGES WERE FORESEEABLE, (B) WHETHER OR NOT SELLER WAS ADVISED OF THE POSSIBILITY OF SUCH DAMAGES, (C) THE LEGAL OR EQUITABLE THEORY (CONTRACT, TORT OR OTHERWISE) UPON WHICH THE CLAIM IS BASED, AND (D) THE FAILURE OF ANY AGREED OR OTHER REMEDY OF ITS ESSENTIAL PURPOSE. FURTHER, IN NO EVENT SHALL SELLER'S AGGREGATE LIABILITY ARISING OUT OF OR RELATED TO THIS AGREEMENT, WHETHER ARISING OUT OF OR RELATED TO BREACH OF CONTRACT, TORT (INCLUDING NEGLIGENCE) OR OTHERWISE, EXCEED THE TOTAL OF THE AMOUNTS PAID TO SELLER FOR THE GOODS SOLD HEREUNDER.

10. Compliance with Law.

Buyer is in compliance with and shall comply with all applicable laws, regulations and ordinances. Buyer has and shall maintain in effect all the licenses, permissions, authorizations, consents and permits that it needs to carry out its obligations under this Agreement.

11. Indemnification.

Buyer shall indemnify, defend and hold harmless Seller and its officers, directors, employees, agents, affiliates, successors and permitted assigns (collectively, "Indemnified Party") against any and all losses, claims, actions, judgments, settlements, interest, awards, penalties, fines, or expenses of whatever kind, including attorneys' fees, fees and the costs of enforcing any right to indemnification under this Agreement and the cost of pursuing any insurance providers, incurred by Indemnified Party and arising out of or resulting from any claim of a third party or Seller arising out of or occurring in connection with the products purchased from Seller or Buyer's negligence, willful misconduct or breach of this Agreement. Buyer shall not enter into any settlement without Seller's or Indemnified Party's prior written consent.



Section 8 – Warranty Statement

12. Insurance.

During the term of this Agreement and for a period of three (3) years thereafter, Buyer shall, at its own expense, maintain and carry insurance in full force and effect which includes, but is not limited to, property insurance against loss, theft, and damage in an insured amount of full replacement value of such CD3 Unit(s); and comprehensive general liability insurance in an amount no less than \$2,000,000. On or before the delivery date, and at such other times as Seller may request, Buyer shall provide Seller with a certificate of insurance evidencing the maintenance of the property insurance and liability insurance. The certificate of insurance shall name Seller as an additional insured. Buyer shall provide Seller with 30 days' advance written notice in the event of a cancellation or material change in Buyer's insurance policy. Except where prohibited by law, Buyer shall require its insurer to waive all rights of subrogation against Seller's insurers and Seller.

13. Confidential Information.

All non-public, confidential or proprietary information of Seller, including, but not limited to, specifications, samples, patterns, designs, plans, drawings, documents, data, business operations, customer lists, pricing, discounts or rebates, disclosed by Seller to Buyer, whether disclosed orally or disclosed or accessed in written, electronic or other form or media, and whether or not marked, designated or otherwise identified as "confidential," in connection with this Agreement is confidential, solely for the use of performing this Agreement and may not be disclosed or copied unless authorized by Seller in writing.

14. Intellectual Property Rights.

Buyer acknowledges and agrees that any and all of Seller's intellectual property rights in the CD3 Unit(s) including any derivative idea, invention or innovation, whether registered or unregistered other than Buyer affixed trademarks or logos ("IP Rights") are the sole and exclusive property of Seller. Buyer shall not acquire any ownership interest in any of Seller's IP Rights under this Agreement. If Buyer acquires any rights in any IP Rights in or relation to any CD3 Unit(s) including any rights in any trademarks, derivative works, related inventions or ideas, such rights are deemed and are hereby irrevocably assigned to Seller without further action by either of the parties.

15. Notices.

All notices, requests, consents, claims, demands, waivers and other communications under this Agreement must be in writing and addressed to the other party at its address set forth on the reverse side of this Agreement (or to such other address that the receiving party may designate from time to time in accordance with this Section). Unless otherwise agreed herein, all notices must be delivered by personal delivery, nationally recognized overnight courier or certified or registered mail (in each case, return receipt requested, postage prepaid). Except as otherwise provided in this Agreement, a notice is effective only (a) on receipt by the receiving party, and (b) if the party giving the notice has complied with the requirements of this Section.

16. No Third-Party Beneficiaries.

This Agreement benefits solely the parties to this Agreement and nothing in this Agreement, express or implied, confers on any other person any legal or equitable right, benefit or remedy of any nature whatsoever under or by reason of this Agreement.

17. Governing Law.

This Agreement and all matters arising out of or relating to this Agreement, are governed by, and construed in accordance with, the internal laws of the State of Minnesota.

18. Force Majeure.

The Seller is not responsible for any failure or delay in performing this Agreement if caused by acts or circumstances beyond the reasonable control of Seller.



EXHIBIT A

LIMITED WARRANTY

Seller warrants to Buyer that for one (1) year following confirmed delivery of the CD3 Unit(s) to the Delivery Point ("Warranty Period"), such CD3 Unit(s) will materially conform to the specifications CD3 Unit model as described on our website (www.cd3station.com) and will be free from material defects in material and workmanship.

Excepted from this Limited Warranty are the tools that are tethered to the CD3 Unit(s) (e.g. brush, wrench and grabber). These items are not covered and routinely need replacement due to normal wear and tear, abuse or misuse. Replacement parts are available from Seller or can be provided as part of an ongoing maintenance agreement.

EXCEPT FOR THE WARRANTY SET FORTH HEREIN, SELLER MAKES NO WARRANTY WHATSOEVER WITH RESPECT TO THE SELLER UNIT, INCLUDING ANY (a) WARRANTY OF MERCHANTABILITY; (b) WARRANTY OF FITNESS FOR A PARTICULAR PURPOSE; (c) WARRANTY OF TITLE; OR (d) WARRANTY AGAINST INFRINGEMENT OF INTELLECTUAL PROPERTY RIGHTS OF A THIRD PARTY; WHETHER EXPRESS OR IMPLIED BY LAW, COURSE OF DEALING, COURSE OF PERFORMANCE, USAGE OF TRADE OR OTHERWISE.

Seller shall not be liable for a breach of the warranty set forth herein unless: (i) Buyer gives written notice of the defect, reasonably described, to Seller within 30 days of the time when Buyer discovers or ought to have discovered the defect; (ii) Seller is given a reasonable opportunity after receiving the notice to examine such CD3 Unit(s); and (iii) Seller reasonably verifies Buyer's claim that the CD3 Unit(s) is defective.

Seller shall not be liable for a breach of the warranty set forth herein if: (i) Buyer makes any further use of such CD3 Unit(s) after giving such notice; (ii) the defect arises because Buyer failed to follow Seller's oral or written instructions as to the storage, installation, commissioning, use or maintenance of the CD3 Unit(s); (iii) Buyer alters or repairs such CD3 Unit(s) without the prior written consent of Seller; (iv) the CD3 Unit(s) has been subjected to abuse, misuse, neglect, negligence, accident, improper handling, abnormal physical stress, or abnormal environmental conditions; or (v) the CD3 Unit(s) has been used with any third-party product, hardware or product that has not been previously approved in writing by Seller.

Subject to the two preceding paragraphs, with respect to any such CD3 Unit(s) during the Warranty Period, Seller shall repair or replace such CD3 Unit(s) (or the defective part).

THE REMEDY SET FORTH IN THE PRECEDING PARAGRAPH SHALL BE THE BUYER'S SOLE AND EXCLUSIVE REMEDY AND SELLER'S ENTIRE LIABILITY FOR ANY BREACH OF THE LIMITED WARRANTY SET FORTH HEREIN.